

# MULTISHEAR<sup>®</sup> MAGNETIC TRAP

MODEL 4 X 4 X 4



Patented



MULTISHEAR<sup>®</sup>  
CORPORATION

# SPECIFICATIONS

## MODEL 4 X 4 X 4

## FEATURES

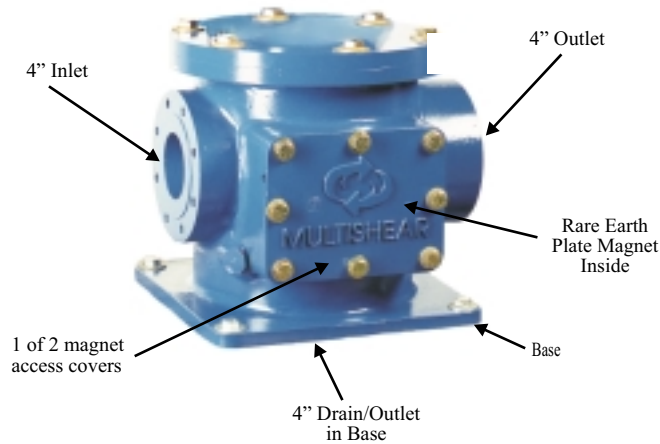

- The MULTISHEAR Magnetic Trap protects your valuable equipment by removing ferrous metals from the stream such as nuts, bolts, ball bearings, etc. The integral junk chamber also allows non-ferrous metals to collect in its bottom section.
- The heart of the trap is a stainless steel plate magnet containing powerful rare earth magnets. A removable stainless steel sheath is furnished to cover the magnet. Tramp metal is easily removed from the plate magnet by lifting the stainless steel sheath to strip the metal from the attractive force of the magnet.

- The magnet is easily accessed and serviced through a removable cover on each side of the unit.
- The unit shown features a 4" inlet, 4" outlet, and a 4" drain/outlet in the bottom of the base.

## CROSS-SECTION

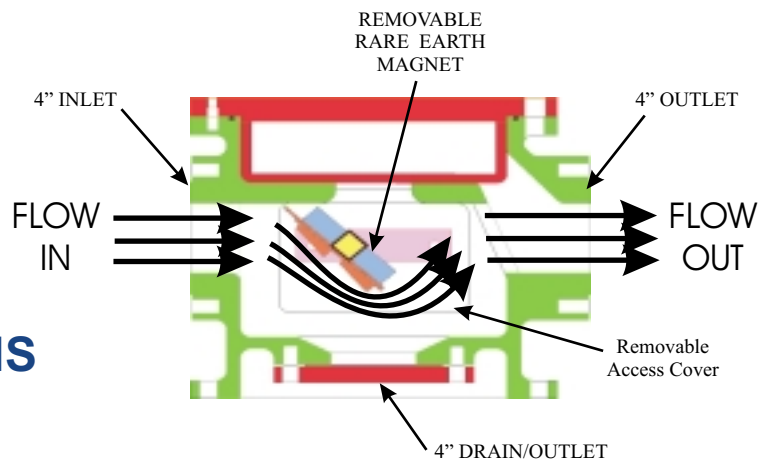

## TYPICAL DIMENSIONS

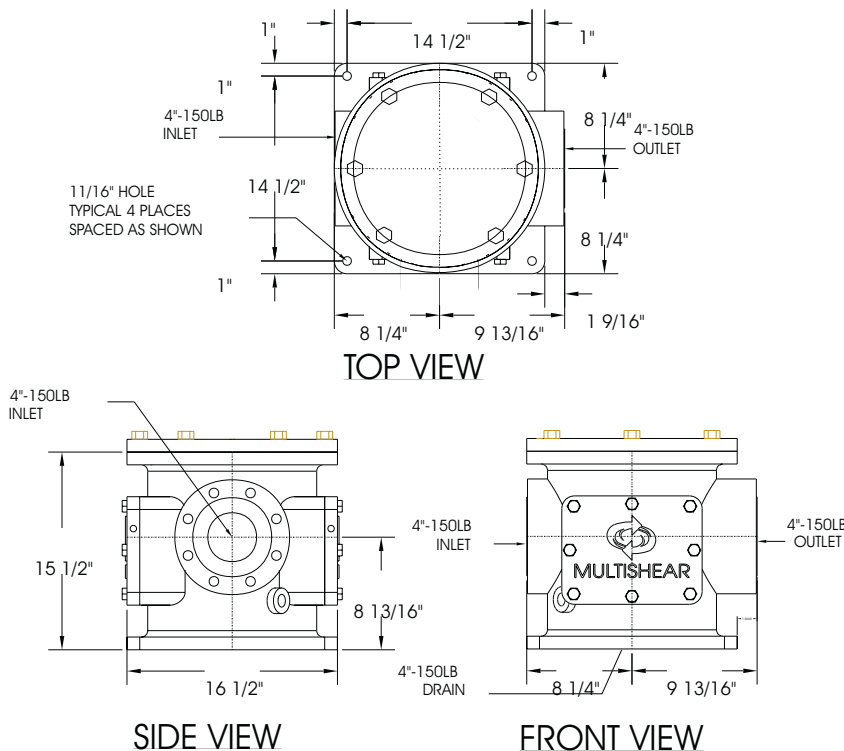

**MULTISHEAR<sup>®</sup>**  
CORPORATION

PH (803) 593-9122

FAX (803) 593-1957

304 MUSTANG DRIVE

GRANITEVILLE, SC 29829

WWW.MULTI-SHEAR.COM